



New LASERLAB™ 3D Inspection Breakthrough!

General Inspection, LLC, located in Davisburg, Michigan, USA has recently unveiled their new LASERLAB™ system for measuring cylindrical parts. Manual gages like micrometers, calipers, ring gages, and optical comparators have been outmoded by an easy-to-use non-contact laser-optics system. Hundreds of thousands of data points per inch mean accuracies beyond even the best Coordinate Measuring Machines.

An un-skilled operator simply places a part on the stage and selects the start icon. The part is immediately followed through the three-dimensional laser scanner by a multi-dimensioned, National Institute of Standards traceable calibration cone. Statistical Process Control sampling and Pre-Production Approval Processing can be done more precisely in a fraction of the time previously taken and the measurements are automatically displayed and kept on permanent record to settle possible dispute.

In the few seconds it takes to scan a part, all dimensions, including lengths, diameters, radii, angles, and external thread measurements are displayed,

accurate to a few microns. Out-of-tolerance features are highlighted in red. A complete roster of all dimensions is displayed for entry into a spreadsheet. After tolerances are assigned with the appropriate part number, they can be stored in memory for quick re-call when that part is to be inspected again.

Fastener manufacturers, screw machine shops, and turned part manufacturers say the LASERLAB™ system will quickly pay for itself from reduced machine downtime and the need for less skilled operators.

General Inspection, working with REMINC engineers have developed the ability to measure key TAPTITE® dimensions using the LASERLAB™ system. The software for checking TAPTITE® products is available in two versions, one version is suitable for and available to REMINC/CONTI licensees only and the second version is designed for end users and distributors. REMINC will have a LASERLAB™ unit installed in their lab to perform quality audits and other dimensional studies on TAPTITE® products".

(cont. on Page 3)

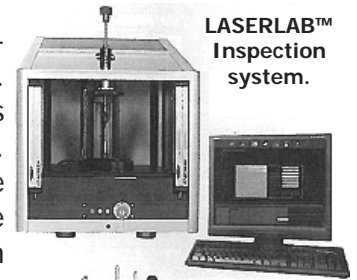

**LASERLAB™
Inspection
system.**



**Samples of
fasteners
inspected by
LASERLAB™.**

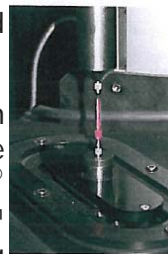

**Fastener
part held
stationary
in LASERLAB™.**



**Stainless steel
calibration cone.**

REMINC STAFF

- | | |
|------------------|-----------------------------------|
| Laurie Mandly | Chairman & CEO |
| Tim Egan | President |
| Ken Gomes | VP - Marketing/Engineering |
| John Reynolds | Mgr. - Fastener Engineering |
| Don Fosmoen | Mgr. - Manufacturing Engineering |
| Dennis Boyer | Senior Project Engineer |
| Bob Budziszek | Lab Technician |
| Suzanne Lilly | Administrator - Int'l. Properties |
| Beth Rondeau | Dir. of Financial Administration |
| Marena Boyadjian | Executive Assistant |
| Ralph Barton | Associate |



SPOTLIGHT ON JOHN REYNOLDS

John is the Manager of Fastener Engineering for REMINC, where he oversees the test laboratory, engineering and product design functions. He is also involved with licensee education and support. John has been with REMINC since 1987 and has 31 years experience in the fastener industry.



PRESIDENT'S PERSPECTIVE - REMINC'S RESPONSE TO GLOBALIZATION by Tim Egan



As we are all experiencing, the manufacturing and assembly of practically all consumer and industrial goods has been globalized to a degree never previously witnessed. Companies are literally jumping from one country to another, seeking lower costs, yet striving to maintain product quality. This phenomenon has forced REMINC to react quickly and expand our support of these activities.

As manufacturers and assemblers migrate to distant locations our licensees have followed them, in order to guarantee high-quality local sourcing of genuine trademarked fasteners. A new licensed fastener manufacturing location places several demands on us as the licensor. The licensee will usually only have a select few employees that have transferred from the base facility on the new site, while the rest are generally inexperienced or simply not familiar with our technology. Therefore TRILOBULAR™ education and training is essential on all levels.

To meet this need, REMINC/CONTI have increased our staff to contact licensees and assemblers now located in Asia and Central Europe, as these two areas in particular, have huge growth potential. We have made a measured effort to regularly visit each of our licensees and make presentations to their marketing, engineering, manufacturing and quality personnel in order to make them knowledgeable and competent in TRILOBULAR™ and REMFORM® fastener technology and their respective cost-saving benefits. On-site visits have proven to be very valuable and preferable to e-mail and fax contacts, especially in situations where language differences prevail. In just the past 12 months we have been very active, not only in Europe and North America, but also in Poland, Czech Republic, Japan, Korea, Taiwan, Malaysia, China and Singapore.

Meeting face-to-face with tooling, engineering and manufacturing people can eliminate start-up quality problems and hasten the licensee's ramp-up to full production. Performing regular quality audits is another tool used to ensure product quality and performance consistency. Meeting with marketing and sales staffs is the quickest way to transfer knowledge and help the licensees' marketing efforts become more effective. REMINC/CONTI have also expanded our program of contacting potential fastener users in remote locations in order to inform them about the merits of thread-forming technology. Our staff is always available and anxious to work with your staff and provide whatever support may be required.

An additional point worth mentioning is the degree to which we attempt to globally protect our intellectual property. We have several patents and trademarks registered in 20 countries, insuring intellectual property security; and this protection comes at a substantial cost. In addition, we monitor non-licensees' market activities and trade journal advertisements, taking appropriate action when necessary to stop the unauthorized use of our intellectual property.

Changing times require modifications to your mode of operation, and we are doing our best to address these new challenges by providing an even higher level of licensee support globally. In this most difficult economic climate we are not cutting back at REMINC/CONTI, but instead making additional investments in our staff and expanding their travel to be sure our licensees are adequately prepared for the business upturn when it occurs.



New LASERLAB™ 3D Inspection Breakthrough! (cont. from page 1)

In order to qualify the LASERLAB™ system for use with TAPTITE® products, several dimensional studies were performed using conventional measuring equipment on both TAPTITE® product blanks and screws. The results were compared for both accuracy and precision with the LASERLAB™ results. From these studies, General Inspection engineers developed the equations necessary to measure TRILOBULAR™ shape product.

LASERLAB™ is able to measure C,D,E and K as shown below with one simple scan. It is also capable of measuring at certain intervals along the fastener body as shown below. This feature is very important as it is able to detect any taper on the fastener.

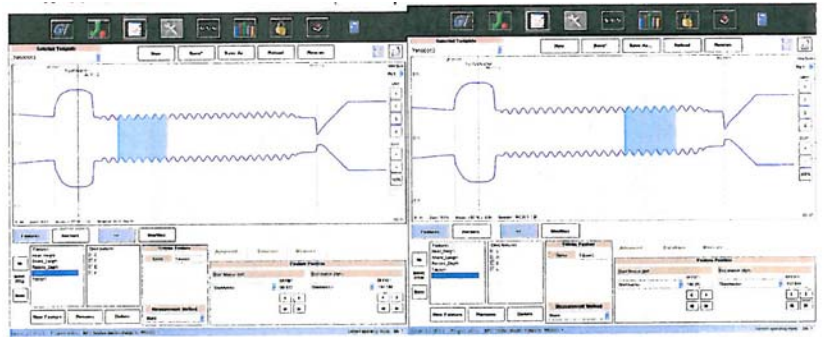
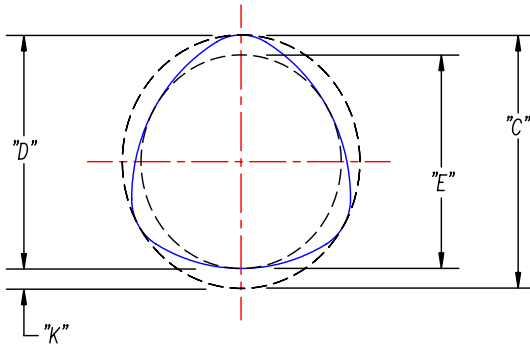

You may want to contact General Inspection for more information. For those readers located in the USA, the General Inspection demonstration van will go to your location for a no-charge demonstration of the LASERLAB™ capabilities. In the USA their toll free phone number is 1-888-817-6314. For those readers located outside the USA, contact General Inspection for demonstration availability at 1 (248) 625-0529.

REMINC Responds! Fielding the Questions

- Q. If a tapped hole is contaminated with paint and will not allow a machine screw to be inserted, what would REMINC suggest?*
- A. REMINC has developed a product called KLEERTITE®. This product is designed with a paint clearing feature, which will scrape away the paint as it is being driven. The fastener will also give good electrical conductivity as it was designed to not only clear away paint contamination but also to serve as a grounding (earthing) screw.
- Q. I have a machine screw application where the screw is constantly coming loose. What would REMINC suggest?*
- A. A POWERLOK® fastener would be the design of choice for this application. It is our all-metal TRILOBULAR™ fastener for use in tapped nut members. The POWERLOK® screw achieves enhanced locking ability through the combination of a novel 60°-30° thread form and a TRILOBULAR™ thread body. The 30° tip penetrates the root of the nut thread as the thread form locking feature. The POWERLOK® fastener resists vibration even when unseated, as the locking feature extends the entire length of the fastener, therefore making it an excellent adjusting screw.
- Q. What are the enhancements incorporated in a TAPTITE 2000® that make it a better performing product than a TAPTITE II® or DUO-TAPTITE® fastener?*
- A. TAPTITE 2000® fasteners were developed with two objectives in mind. First, we wanted to achieve a thread forming torque which would be lower than that of TAPTITE II® fasteners. Second, we wanted to maintain or increase the high failure torque attained with DUO-TAPTITE® fasteners. During the design process the stabilizing feature was enhanced to lower the end load required to start thread forming. Additionally, a unique thread form was developed which has contributed to achieving efficient torque-tension relationships. All of the above features combined in TAPTITE 2000 fasteners have provided performance characteristics that make it the best thread forming fastener on the market today.

REMINC Training / Brochure Request Form

Name:

Company:

Address:

Please Check:

- Contact me regarding a training visit
- REMINC General Products Catalog
- TAPTITE 2000® Products Application Guide
- TAPTITE 2000® Product Brochure
- REMFORM® Product Brochure
- TRU-START® Product Brochure
- FASTITE® 2000™ Product Brochure
- "54 Ways TAPTITE 2000® Fasteners Lower the Cost of Assembly" Request Form
- Receive Newsletter by e-mail

Mail this form to REMINC at 55 Hammarlund Way, Tech II, Middletown, RI 02842 USA or fax it to (401) 841-5008

The following are patented products and/or trademarks licensed by REMINC:
TAPTITE®, TAPTITE II®, TYPE-TT®, DUO-TAPTITE®, CORFLEX®, PLASTITE®, POWERLOK®, TRILOBULAR™,
KLEERTITE®, REMFORM®, THE CONTROLLABLE PRODUCT®, ENGINEERED FASTENINGS®, EXTRUDE-TITE®,
KLEERLOK®, MAGTITE®, TAPTITE 2000®, FASTITE® 2000™, TAPTITE 2K®, TYPE TT 2000®,
TYPE TT 2K®, TAPTITE 2000 & DESIGN®

LASERLAB™ is a pending trademark of GENERAL INSPECTION, LLC

COPYRIGHT 2009, RESEARCH ENGINEERING & MANUFACTURING INC.
ALL RIGHTS RESERVED

No part or contents of this newsletter may be reproduced without the expressed written consent of
Research Engineering & Manufacturing Inc.



Research Engineering &
Manufacturing Inc.

55 Hammarlund Way, Tech II
Middletown, RI 02842, U.S.A.

Tel: (401) 841-8880

Fax: (401) 841-5008

E-mail: reminc@reminc.net

*For more information on our
products, visit us at taptite.com*

1958 - 2009

**Celebrating 51 Years Lowering
the Cost of Assembly**

